

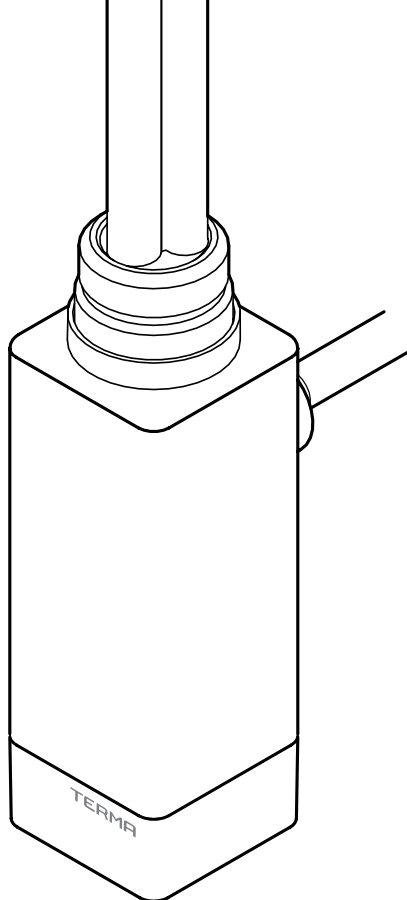

TERMA

SINCE 1990



ONE

User Manual

Electric Heating Element

Electric radiator & Electric Heating Element

General rules.

1. Electric heater is not a toy. Children under the age of 3 should not be allowed within close proximity of the device without the supervision of an adult.
2. Children aged 3 to 8 should only be allowed to operate the heater when it has been properly installed and connected. The child must be under adult supervision or have been trained to safely operate the device while understanding the risks.
3. Some parts of the radiator can be very hot and can cause burns. Pay special attention to ensure the safety of very small children or people with disabilities, install the electric radiator so that the lowest tube is at least 600 mm above the floor.
4. The device should only be installed by a qualified installer in accordance with the applicable regulations regarding safety and all other regulations.

Notes for safe installation.

⚠ IMPORTANT-PLEASE READ.

Changes to Building regulations.
Please note that the information is given guidance only.

As of 1 January 2005, changes to the Building Regulations affected domestic electrical installations in England and Wales. You do not need to be a qualified electrician to make changes to your home's electrical system, but the work must be done in accordance with the standards in the Regulations. In order to make sure that you comply with the latest regulations regarding electrical work carried out in a dwelling go to www.planningportal.gov.uk

1. The electric installation to which the heater is connected should have a current differential relay (R.C.D.) of 30 mA and the right overcurrent relay. With the permanent installation (cable connection without plug) it is also mandatory to have an omni-pole cut-out for disconnecting the device on all poles, by points of contact with the clearance of 3 mm.
2. All of our heating elements are factory tested and in full working order when they are despatched. Although not advisable, should you be required to test the heating element prior to full installation make sure that the test is carried out in the open air and that the heating element is only

on for a maximum of 3 seconds. **BEWARE! DURING THIS TEST THE HEATING ELEMENT WILL GET VERY HOT ALMOST IMMEDIATELY; ONLY HOLD THE UNIT BY THE BASE, DO NOT TOUCH THE ELEMENT AND DO NOT PUT DOWN UNTIL COOL ENOUGH TO DO SO.**

3. The device is suitable for connection in zone 3, as defined by applicable regulations, unless otherwise specified by regulations applicable in the country of installation and use. Attention: the device must be installed out of reach of persons in the bathtub, shower or pool.

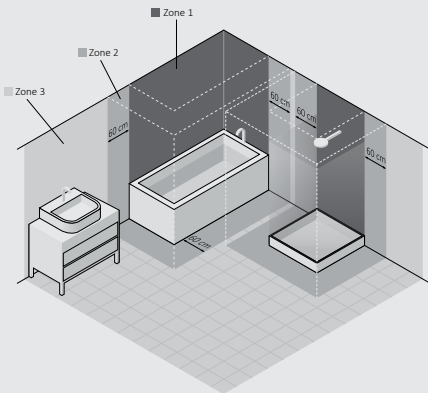

4. **ELECTRIC RADIATOR ONLY** - Your radiator should be filled with a carefully measured amount of liquid. In the case of loss of heating liquid, or in any other

case which demands its replacement, contact your supplier.

5. The device is not equipped with an external temperature controller. Do not use the device in a small room if unsupervised disabled or incapacitated individuals are inside it. Only use the device if those individuals are under constant supervision.
6. If the device is used as a clothes and towel dryer, ensure that the fabrics drying on it have only been washed in water, avoiding contact with any harsh chemicals.
7. Connect the unit to a sound electrical installation (see the ratings on the heater).
8. All installations to which the device is connected should comply with regulations applicable in the country of installation and use. Extension leads or electric plug adapters should not be used in order to supply power to the heater.
9. Ensure that the heater has been installed on a wall in accordance with its installation manual.
10. Before installing or removing the device, make sure it is disconnected from the power source.
11. Please forward this instruction manual to the end user.

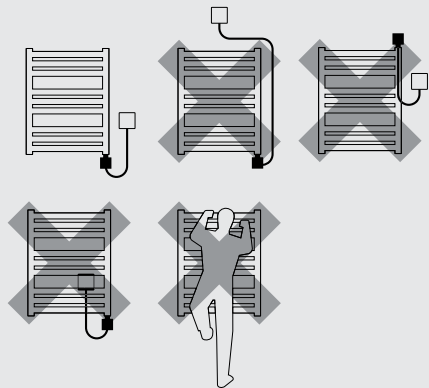

Notes for safe use.

1. The heating element's power output must not exceed the radiator's power output for the parameters 75/65/20° C.
2. The pressure in the radiator should not exceed 10 bar. Ensure that an air cushion is preserved in electric radiators.
3. When heating a radiator as part of a dual fuel heating system always leave the flow and return valves open on the radiator that it is fitted to in order to prevent pressure build up due to the thermal expansion of the liquid.
4. Do not turn the heating element on in an empty radiator!
5. The heating element must be fully submerged in the heating liquid during its operation.
6. Ensure that the power cord does not touch the hot parts of the heating element or radiator.
7. The device is intended for home use only and is recommended for use solely as described in the manual.
8. Regularly check the device for damage to ensure it is safe to use.
9. If the power cord is damaged the device should not be used. Disconnect the device from the supplying net and contact the manufacturer or distributor.
10. Do not allow flooding into the heating element casing.
11. Do not use the heating element in heating systems where the water temperature exceeds 82° C.
12. The heating element and radiator can heat up to high temperatures. Please be cautious — avoid direct contact with the hot parts of the equipment.
13. Do not open the device — any interference with internal components will invalidate the warranty.
14. Ensure that minors aged 8 and above or those with a physical or mental disability are supervised if operating the device.
15. The device must be disconnected from the mains during cleaning and maintenance.
16. Cleaning of the equipment by children under 8 years of age is only permitted under appropriate supervision.

Installation

Electric only Radiator

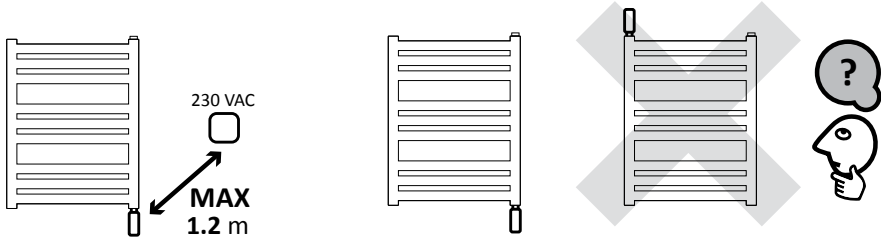

1. Correct placement and position of the radiator and heating element.

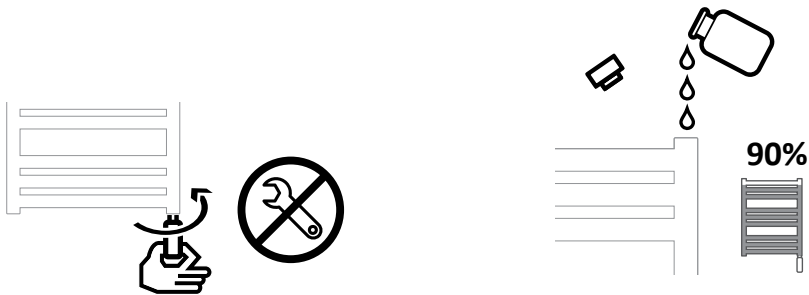

2. Install and tighten by hand only.
3. Fill the radiator with a proper heating agent.

Use a suitable heating liquid for filling the electric radiator, (i.e.) water, special products based on water and glycol for use in central heating systems, or oil which complies with the requirements of the manufacturer of the radiator and heating element. When filling the radiator with hot liquid insure that the liquid temperature does not exceed 65° C.

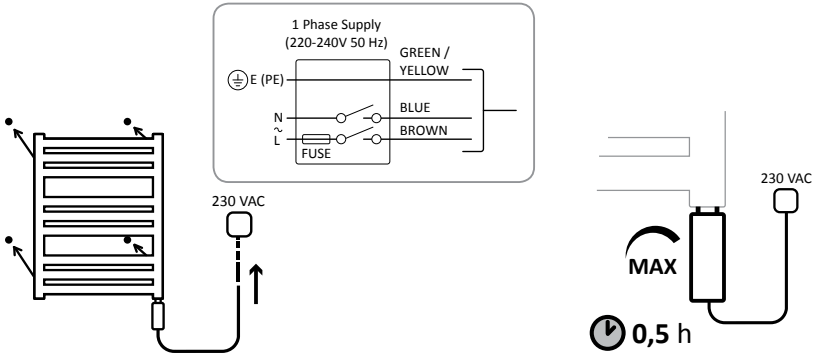

4. Fit the radiator on the wall and connect the heating element to the power supply.

5. Set the heater on max and keep it for 30 min. (the plug opening must be open).

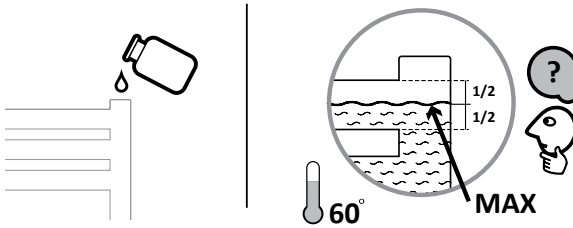

6. Check the level of the hot heating agent inside the radiator, add more if needed.

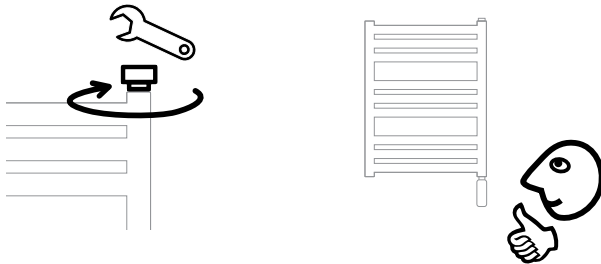

7. Close the radiator plug.

8. Your radiator is ready.

Dual Fuel Radiator

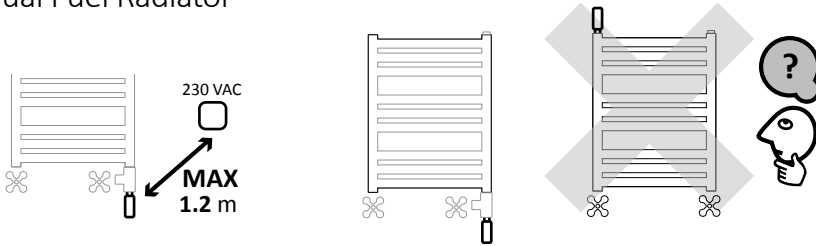

1. Correct placement and position of the radiator and heating element.

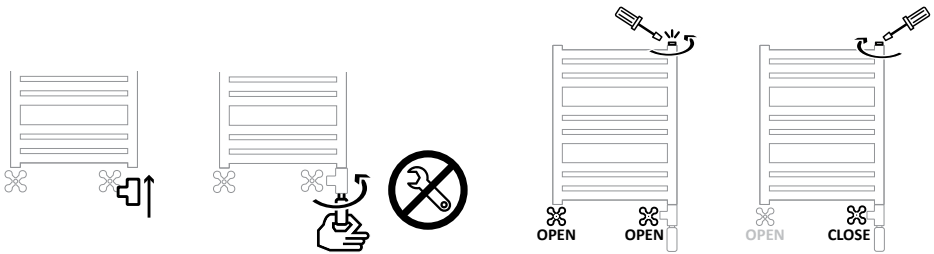

2. Fit the T-fitting to the radiator and then install the heating element. Install and tighten by hand only.
3. Fill the radiator with the water, then bleed it. Once bled make sure that the flow and return valves are both open. NEVER OPERATE THE HEATING ELEMENT WITH BOTH THE FLOW AND RETURN CLOSED AS THIS WILL CAUSE A PRESSURE BUILD UP DUE TO THERMAL EXPANSION AND MAY CAUSE DAMAGE TO THE HEATING ELEMENT.

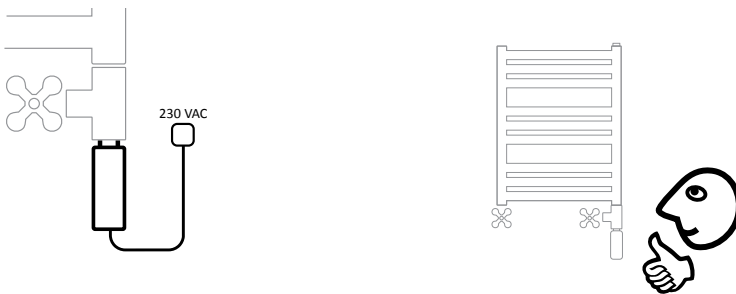

4. Connect the heating element to the power supply.
5. Your radiator is ready.

When using a dual fuel system it is inefficient and impractical to heat your radiator using the heating element and your central heating at the same time.

ONE

Functions and use

The 'ONE' heating element has two radiator temperature settings (45° C and 60° C) as well as an automatic 2 hour timer that will switch off the element.

The on/off button is also used to change settings which are identified by using different colours of the LED diode.

The device has a built-in infrared receiver (IR) for communication with a TERMA external controller such as DTIR and TTIR, both of which will provide additional functions to the element.

Anti-freeze function

When the heating agent's temperature inside the radiator drops below 6° C, the device will switch on automatically. This is indicated by a LED diode flashing rapidly every 4 seconds.



For more information about the 'ONE' functions and features please visit:
en.termaheat.com/grzalka/one-k-30x30

On/off button

Turning the device on will result in the radiator heating up to the set temperature (45/60° C).

After reaching the set temperature the device will turn off and on regularly in order to maintain the set temperature.

Changing the settings of heating element

Pressing the on/off button will change the setting, pressing once to turn it in, again to change the temperature and again to turn it off.

1. Turning on – heater is automatically set to 45° C - yellow light;
2. Increasing temperature to 60° C – red light;
3. Turning off - diode is not on.

The previous settings are always remembered if the electricity is cut-off.

Automatic switch-off (timer)

Press and hold the on/off button — the heater starts working for 2 hours on setting 60° C, after which it switches off. Active TIMER is indicated by pulsating diode.

Regardless of current heating element setting, the TIMER can be activated by pressing and holding the on/off button.

Quick pressing of the button will turn off the heating element.

Remote control mode (Infrared communication)

The 'ONE' is pre configured to work with Terma IR controllers (DTIR and TTIR).

If there is a dedicated IR controller inside the room which sends signals to the heating element, then, the first signal correctly received by the heating element, automatically switches the device into receiving mode.

Remote mode is indicated by the diode shining with constant blue light.

When in this mode, the heater will heat with the heat output controlled by the external IR controller while still regulating the temperature not to exceed approximately 60° C.

Every correctly received signal from the external IR controller is indicated by short flash of the diode. If there is a break in communication (the heater does not receive a signal from the external controller for 30 minutes), the heater will switch to a signal awaiting mode. The blue diode will start pulsating steadily and the heater will automatically turn off with the antifreeze function still active until the connection is reached again.

The TIMER function in the 'ONE' can also be used in 'remote mode' (in such a case, after the timer operation has seized, the heater will not turn off but it will return to the remote control operation).

Notes prior to removal:

1. Before dismantling permanently, disconnect the heating element from the mains and ensure that the radiator is not hot.
2. Be aware. A radiator filled with liquid can be very heavy. When moving the radiator, ensure that you take the necessary safety precautions.
3. Before disassembly, close the appropriate valves and drain the radiator completely to avoid causing any damage.

Product disposal



This product should not be disposed of as general waste but should be brought to the appropriate collection point for recycling of electric and electronic devices.

This information is provided by the sign on the product, user manual and packaging. Information on the appropriate point for used devices can be provided by your local authority, product distributor or the store from where the product was purchased.

Thank you for your effort towards protecting the environment.

Maintenance

- Before performing maintenance, always unplug the unit from the mains system.
- Periodically check the fluid level in the radiator and ensure the heating element is completely submerged.
- Clean the product with a dry or damp cloth. If necessary, use a very small amount of detergent, ensuring that it contains no solvents or abrasives.

Intended use of device

The heating element is an electric device intended solely for installation in radiators (standalone or connected to the central heating system).

Heating element power output should be matched with radiator output for parameters of 75/65/20° C.

Technical information

Model markings (power cable type):	PB (Straight cable without plug)				
Type of electrical connection:	hard wired connection to electrical system				
Heat outputs available:	200, 300, 400, 600 [W]				
Power supply:	230 V / 50 Hz				
Insulation class:	Class I				
Towel rail connection thread:	G 1/2"				
Casing protection class [IP]:	IPx5				

	200	300	400	600	[W]
Length of heating element (TUBE):	275	300	335	365	[mm]
Total length:	357	382	417	447	[mm]

Troubleshooting

The 'ONE' constantly monitors all of its parameters so that it can indicate if it is damaged or not working correctly due to an internal fault. If a problem is found it automatically activates any necessary protective procedures.

Symptom		Possible cause	Solution
LED diode is not on, heating element does not heat		Damaged electronics	contact Your local Distributor
LED diode pulsing: WHITE & RED or WHITE & YELLOW		The radiator is not warming up quickly	1. Check and confirm that the heating element's output is not too low for the size of radiator. 2. (Dual Fuel only) - check the flow of the heated water, is it flowing back into the central heating system, if this is the case you will need to close one of the valves (flow or return). In the case of a 'side connection' you will need to close the upper valve. If the problem continues contact your dealer.
LED diode pulsing WHITE (malfunction alert)	TWO flashes	Low water level (work in dry conditions)	1. May happen once or twice after switching on - this is not a malfunction; 2. If lasts longer - check the lever of heating agent level.
	THREE flashes	Overheating	Check and reduce the water temperature in the central heating system-must not exceed 82 deg. Check and confirm that the heating element's output does not exceed the recommended output of your radiator. Turn the heating element off with the ON/ OFF button and wait for 20 min. If the radiator is still hot, disconnect it from it's electrical supply - contact the Distributor.
	FOUR flashes	Temperature sensor damaged	Contact Your local Distributor
	FIVE flashes	The radiator is not warming up quickly	1. Check and confirm that the heating element's output is not too low for the size of radiator. 2. (Dual Fuel only) - check the flow of the heated water, is it flowing back into the central heating system, if this is the case you will need to close one of the valves (flow or return). In the case of a 'side connection' you will need to close the upper valve. If the problem continues contact your dealer.
BLUE diode does not light (lack of IR communication)		Problem in the external programmer	Check the batteries Place the programmer close to the heating element and change the temperature setting - if the devices communicate correctly, LED diode lights blue and blinks after each order correctly received.
		Problem with the heating element	contact the Distributor
YELLOW and RED diode light but radiator still cool		Thermal fuse or electronics damaged	contact the Distributor
BLUE diode lights but radiator still cool		Room temperature is equal or higher than the one set in external programmer	Everything is working. To make the heating element heat you may turn on the ON mode in external programmer or the Dryer mode in the element. (Note: Turning the controller 'OFF' will not terminate the connection between the heating element and the controller the only way to do this is to remove the batteries from the controller or move it to another room).
BLUE diode pulsing		The heating element is no longer communicating with the IR controller	Is the controller still in 'line of site' of the heating element or is it being blocked by an object or has it been placed in another room, clear the obstruction or move the controller. Check the batteries. If not and the problem still exists - contact the Distributor.

The construction of the device as well as the physical characteristics of the heating agent inside the radiator, influence the way in which the heat is distributed — It is normal for the two bottom pipes of the radiator to be at a lower temperature than the rest of the radiator.

